

# EBSRAY PUMPS

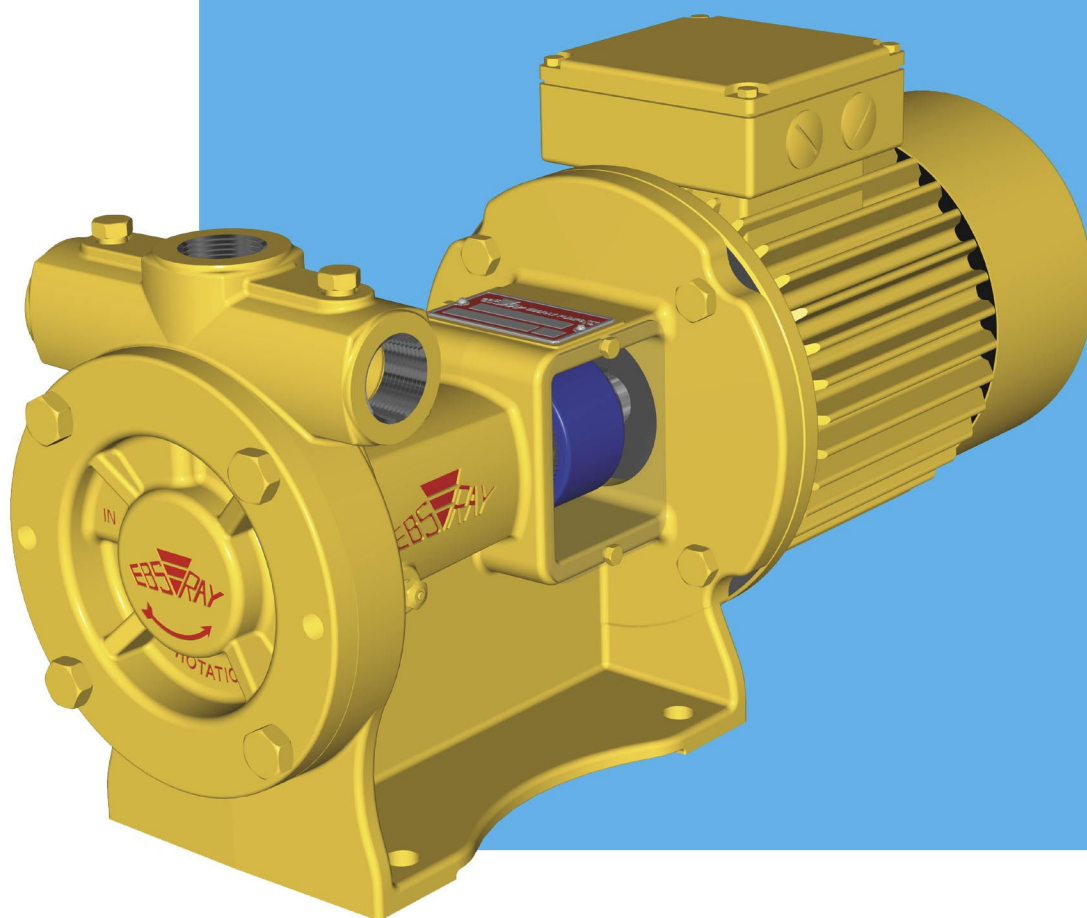

**UK Distributor**

t: +44 (0)1388 813433  
f: +44 (0)1388 813307  
sales@orangecounty.co.uk  
www.orangecounty.co.uk

## ***R Series***

## ***Models RC20 & RC25***

### ***... for LPG Applications***



Quality  
Endorsed  
Company  
ISO 9001  
Lic 3332  
Standards Australia

Head Office and Works



# R Series Models RC20 & RC25



THE EBSRAY MODEL RC SERIES REGENERATIVE TURBINE PUMPS are designed and precision built for high pressure transfer of LPG, Propane, Butane, Autogas, DME etc.

## SPECIFICATIONS

Max Flow @ 2900 RPM	RC20: 50 L/min RC25: 90 L/min
Max Diff' Pressure	1000 kPa (10 Bar)
Pump Speed (Max)	3500 RPM
Power Range	1.5, 2.2, 3.0 kW Motors
Port size (inlet/outlet)	1" NPT 90° and/or 180°
Static Test Pressure	7000 kPa (70 Bar)
CE/ATEX marking	II 2Gc T4 CE

## FEATURES

- ▶ Quiet, vibration free operation
- ▶ Low maintenance - single stage impeller
- ▶ Close Coupled to standard IEC frame B5 Flange mounted 2-pole motors-EEExe or EExd protection
- ▶ Simple installation, rigid mounting
- ▶ Versatile 3-port arrangement - self venting design
- ▶ Bypass Valve connection port direct on pump
- ▶ Balanced Mechanical Seal - unique cartridge design for simplicity of assembly / maintenance
- ▶ Pressure Casings Ductile Iron ASTM Grade A395
- ▶ Throttle Bush - increased safety meets API 682-ISO 21049
- ▶ CE marked, ATEX compliant

## TYPICAL SERVICES

- Autogas refuelling
- Cylinder filling
- Portable tanks
- Marine dispensing
- Direct burner/vaporiser feed
- Forklift refuelling
- Aerosol industries
- Industrial dispensing
- Driveway dispensing- up to 2 hoses (RC25)

## ASSURED QUALITY AND PERFORMANCE

EBSRAY's ISO 9001: 2000 Quality Management System assures compliance with the high safety and quality standards demanded by the LPG industry.

All EBSRAY RC Series pumps are hydrostatically tested after assembly. They are then run tested to simulated duty point prior to dispatch to guarantee pump integrity and performance in accordance with the specifications.

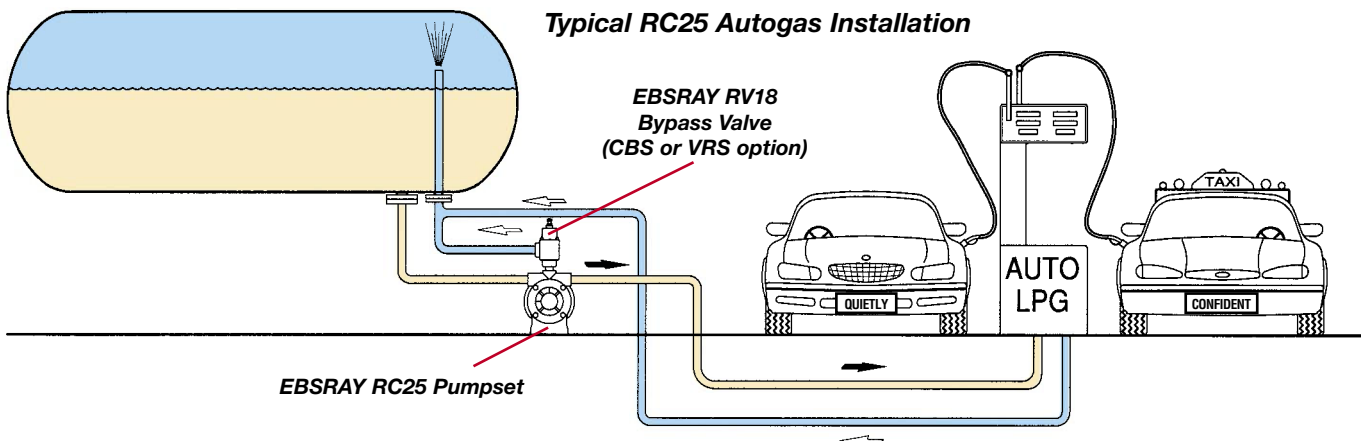

# Features



## PORTS

- 3-Port, 90° and/or 180° configuration – NPT screwed
- Self-venting design for rapid priming
- ‘Spare’ discharge port for Bypass Valve attachment
- Inlet / Discharge gauge tappings

## IMPELLER

- Axially self-aligning, single stage, hydraulically balanced
- Quiet, vibration-free operation
- Tough Gunmetal Bronze material (Cast Iron optional)

## SHAFT

- Rigid design, low deflection
- High tensile alloy steel
- Precision ground surfaces
- ‘Quill’ concept facilitates one-piece assembly of Shaft, Cartridge, Mechanical Seal and Bearings independently of pump, or stocked as a ‘spare part’

## SHAFT SEAL

- Unique, simple assembly – for rapid in-situ servicing
- Carbon / Niresist ‘balanced’ sealing faces – precision lapped
- ‘O-Ring’ sealed
- Circlip location for fixed axial seal setting position
- Positive ‘pin’ drive facilitates assembly simplicity
- Throttle Bush for increased safety - complies with API 682-ISO 21049

## CARTRIDGE

- New concept for ultra-simple field maintenance incorporating:
  - Ability to pre-assemble Seal Seat in Cartridge outside of pump
  - Throttle Bush for increased safety - complies with API 682-ISO 21049
  - Secondary Shaft Seal in Viton for extra protection to Ball Bearing
  - Tough Gunmetal Bronze material (Cast Iron optional)

## SHAFT COUPLING

- Flexible Coupling - non-sparking ‘Polygear’ as standard option CE/ATEX compliant
- Other types of flexible coupling available
- Non-sparking Coupling Guard standard supply

## BEARINGS

- Heavy Duty, deep groove Ball Bearings
- Grease packed, sealed-for-life
- Extra protection by secondary Shaft Seals against dust or LPG entry

## CASING/BODY

- Compact, one-piece design
- Mounting flange for close-coupling IEC B5 frame motors
- Robust construction for motor and pipeline stability/rigidity
- Ductile Iron to ASTM A395
- ‘O-Ring’ sealed, simple to service
- Hydrostatically tested to 70 Bar after assembly

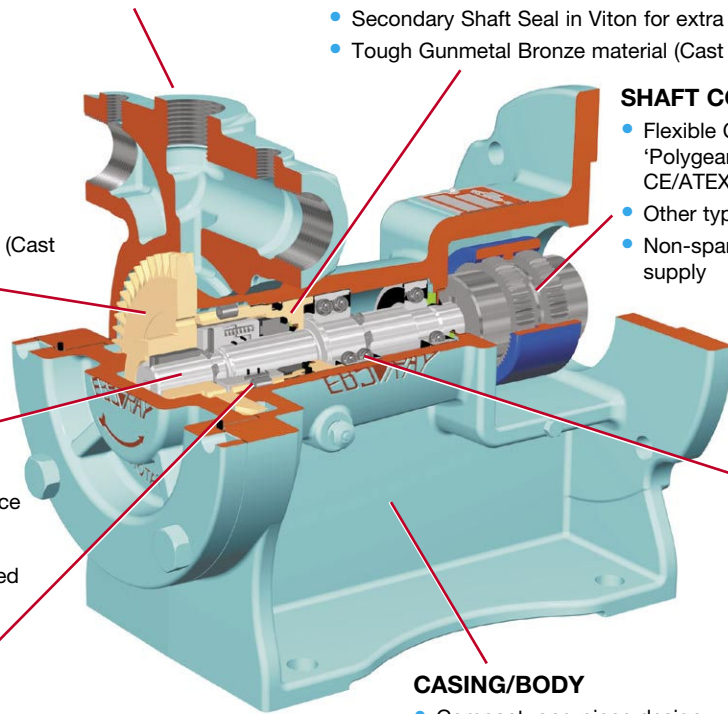

# Performance at 2900 RPM

RC20

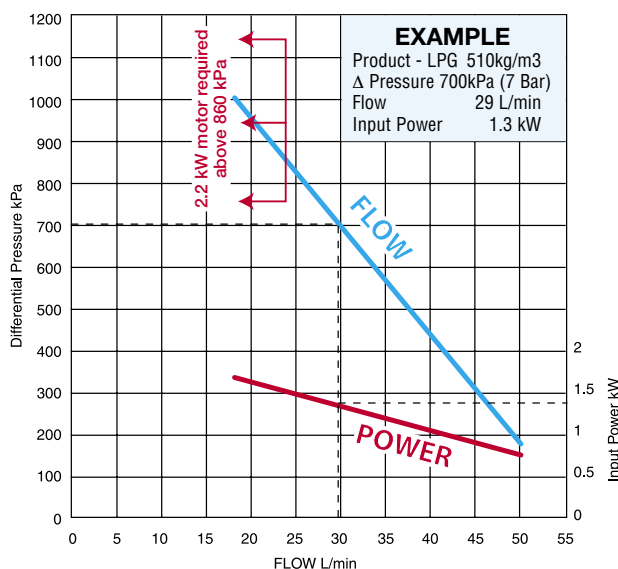

RC25

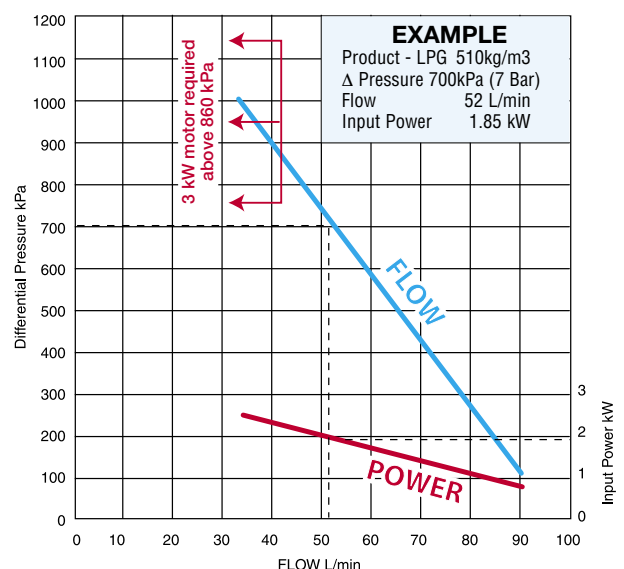

**Note:** For 60 Hz (3500 RPM) operation, Refer to specific performance curve

# Dimensions Models RC20 & RC25

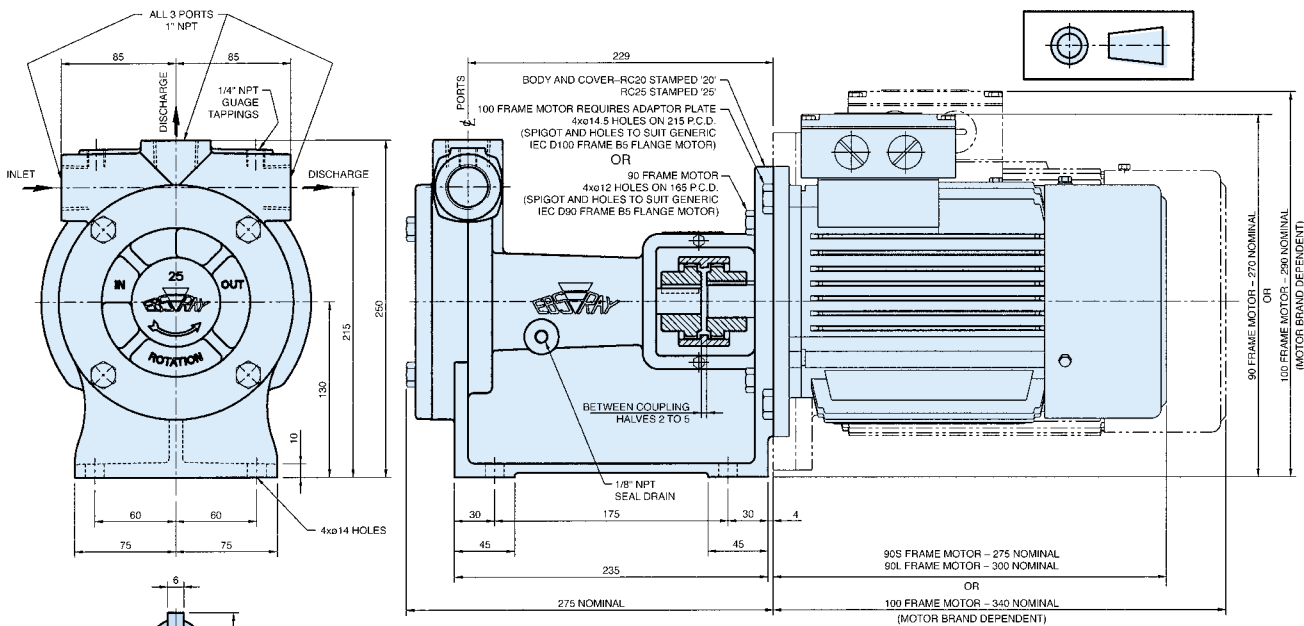

PUMP WEIGHT: 19.5KG  
PUMPSET WEIGHT: 19.5KG + MOTOR WEIGHT

## Parts Designation

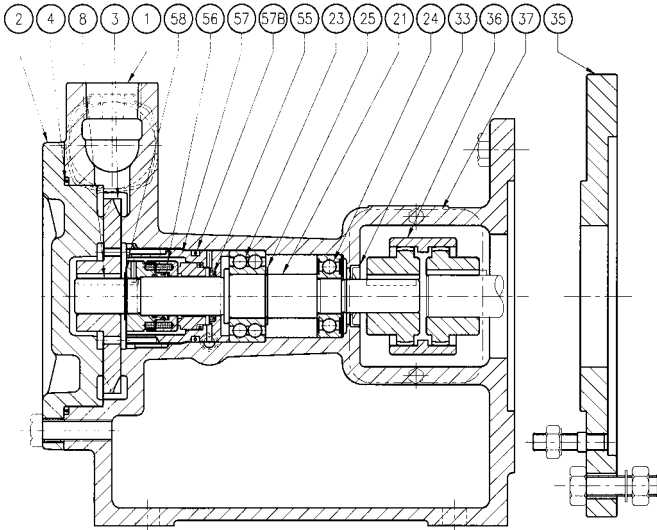

Cat#	Description	Material	Qty
1	Body	Ductile Iron	1
2	Cover	Ductile Iron	1
3	Impeller	Gunmetal	1
4	O-Ring - Cover	Nitrile	1
8	Impeller Key	Steel	1
21	Shaft	Alloy Steel	1
23	Ball Bearing	Commercial	1
24	Ball Bearing	Commercial	1
25	Circlip	Spring Steel	1
33	Dust Seal	Nitrile	1
35	Motor Adaptor Kit		1
36	Coupling Assembly	Steel/Nylon	1
37	Coupling Guard	Aluminium	2
55	Secondary Seal	Viton	1
56	Mechanical Seal Assembly	Carbon/Niresist/Nitrile	1
57	Cartridge	Gunmetal	1
57B	O-ring - Cartridge	Nitrile	1
58	Circlip	Spring Steel	1

**Note:** All specifications and illustrations are typical only and subject to revision without notice.  
Certified data available on request

DISTRIBUTED BY:



**UK Distributor**

t: +44 (0)1388 813433

f: +44 (0)1388 813307

sales@orangecounty.co.uk

www.orangecounty.co.uk

## EBS-RAY PUMPS PTY. LIMITED

ABN 52 000 061 003

Head Office and Works  
628 Pittwater Road  
Brookvale NSW 2100  
Australia.

Branch Office Victoria  
Phone: (03) 9706 7263  
Fax: (03) 9706 7312

Telephone: (+612) 9905 0234  
Fax: (+612) 9938 3825  
www.ebsraypumps.com.au

Branch Office Queensland  
Phone: (07) 3260 7411  
Fax: (07) 3260 7422



Quality  
Endorsed  
Company

ISO 9001  
Lic 3332

Standards Australia

Head Office and Works

