

Overfill Prevention (GWG) and its Components

Overfill Prevention Sensor (GWG)  1.1 

Plug Connection  1.2 

Overfill Prevention Sensor Testing Device  1.3 

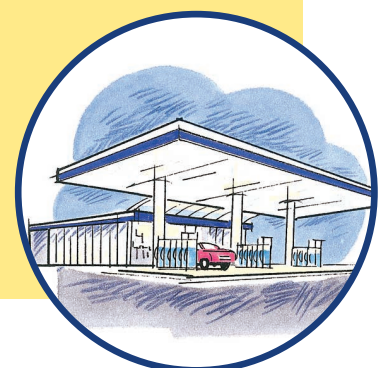

The Overfill Prevention Sensor GWG and QSS/ASS Plugs

The filling sensor is a safety mechanism to prevent overfilling of storage and bunker tanks when they are filled with gasoline, diesel, and fuel oil from road tankers. It consists of a level sensor inside the tank and a amplifier with valve inside the road tanker.

The QSS/ASS plugs are part of a safety system that prevents the blending of products due to a faulty connection and that checks the hose connection to the road tanker during the filling process.

The overfill prevention sensor GWG with tube plug type 907



Advantages of FAFNIR's Technology

- Space-saving, robust and corrosion-free design
- Easy adjustment for different tank sizes
- Sensor without moving parts
- Totally maintenance-free
- Measuring principle tested and tried a million times under the most difficult conditions
- More than 25 years of FAFNIR-experience using this technology
- Integrated QSS and ASS function
- Certified according to ATEX
- In compliance with the German Design Certification according to TRbF 511 and TRbF 512
- Certified as filling sensor in Belgium, Germany, Austria, Poland, Czech Republic, Sweden

Our Terminology

Overfill prevention sensor: GWG
Quality assurance system or product detection: QSS
Filling hose safety device: ASS

Function

The electrical connection to the amplifier is made with the connection cable and coupling type 903 of the road tanker. This connection cable supplies the GWG with intrinsically safe electric current. In addition, it carries the signals for the QSS and ASS function. The threshold point of the GWG inside the tank includes a PTC-resistor. The PTC-resistor is a variable resistance in relation to the rising temperature.

The Filling System

TRbF 511/512

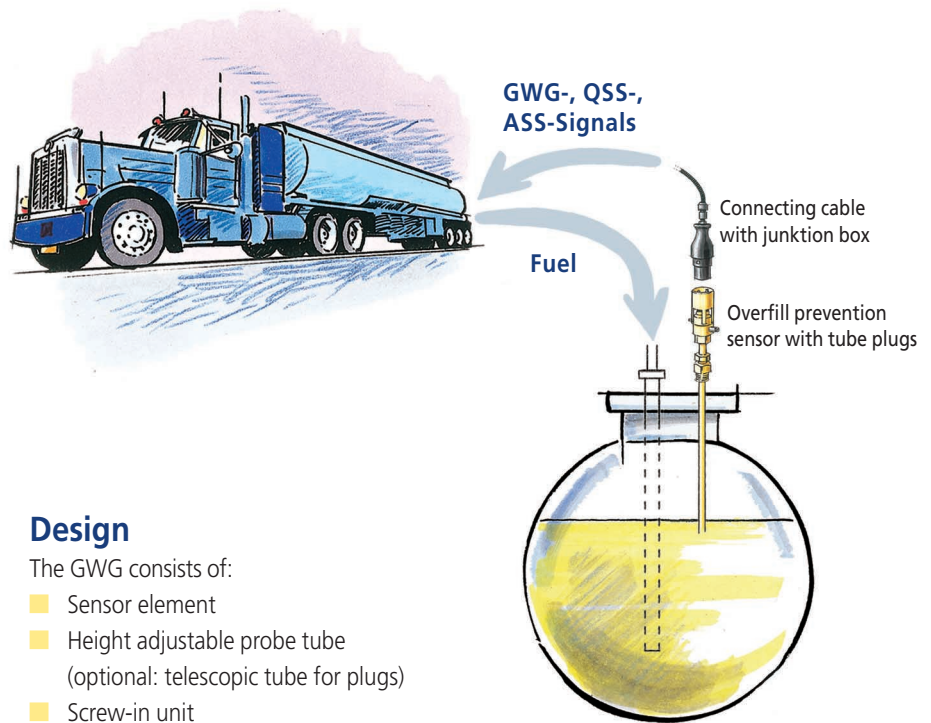

As liquids are better thermal conductors than air or gas, the PTC-resistor heats up better in air or gas. When dipped into liquid, the PTC-resistor is cooled down, and the changing resistance value is interpreted by the amplifier. The amplifier controls a solenoid valve which is part of the control chain of the valve. If the threshold point of the GWG is dipped into liquid, the valve is closed automatically. The filling process is completed.

The QSS functions are carried out by the simple pairing of magnetic reed sensor-codings between plug and coupling. The ASS function is based on checking the closed circuit between amplifier, connection cable, GWG, filling nozzle, filling hose and hose connection in the road tanker.

Installation Possibilities

Three different designs are available. With the GWG with pipe plugs type 907, the connection cable of the road tanker can be connected directly to the tank. There is a design with a fixed or a telescopic probe tube permitting a variable height adjustment of the tube plugs above the screw-in unit.

If the road tanker cannot be connected directly to the tank, the connection is made with the wall plugs, type 907, which are mounted in the area of the filling connection, and connected to the GWG via a two-wire cable. The threshold length to be maintained for each tank, can be easily adjusted by shifting the probe tube inside the screw-in unit.

Design

The GWG consists of:

- Sensor element
- Height adjustable probe tube (optional: telescopic tube for plugs)
- Screw-in unit
- Plugs: optional
 - Tube plugs with flanged plug-in unit and protective basket
 - Junction box for long distance connection
- Separate wall plugs with flanged plugin unit and protective basket

Process Connection

The GWG is supplied with one screw-body G1.

Technical Data

Operating data:

- Product temperature: -25 °C to +50 °C
- ambient temp: -25 °C to +70 °C
- Operation pressure in tank: unpressurized
- Test pressure: 0.67 (approx. 9 p.s.i.) to 2 bar (approx. 29 p.s.i.)
- Applied substances: see List of Substances
- Switching delay for threshold: < 2 seconds
- Protection type of housing: IP 68

Materials:

- Parts in contact with product: brass, stainless steel, galvanised spring steel, solder, viton, ultradur
- Plugs: brass and nickel-plated brass

Dimensions:

- Tube diameter: brass 24 x 2, stainless steel 24 x 1
- Lengths of probes: 100 mm to 3,000 mm, standard: 400 mm to 1,000 mm in steps of 100 mm
- Other data: see illustration

List of Substances

- Gasoline according to DIN 51600/51607 in tanks covered with more than 300 mm of earth
- Diesel according to DIN 51601/51606
- fuel oil according to DIN 51603

GWG with tube plugs

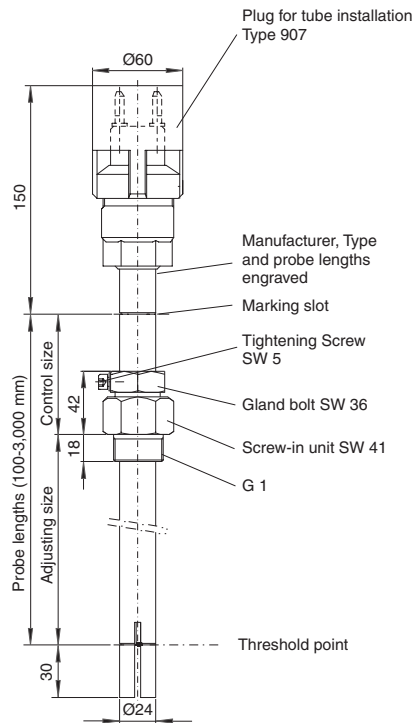

GWG for remote installation with wall plugs

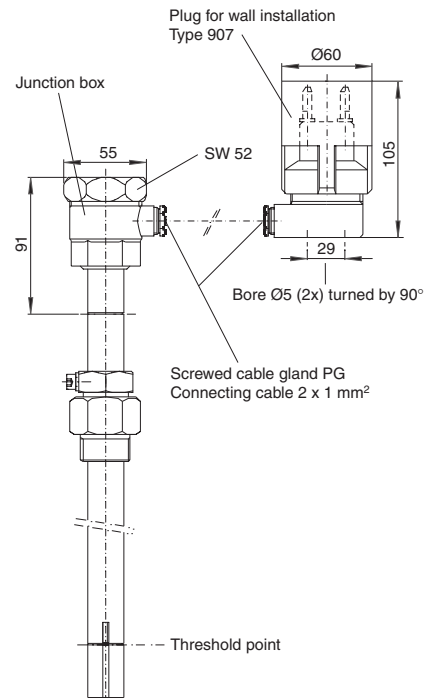

Dimensions in mm

Extended List of Substances for Type 81 D-Ex, 81 D-Ex U

- gasoline according to 51600/51607, aviation gasoline, aviation turbine kerosene
- Special fuels: petrolic ether according to DIN 51630, boiling point benzines according to DIN 51631, test benzines according to DIN 61632, safety lamp fuels according to DIN 51634, FAM regular gasoline according to DIN 51635, lamp, petroleum for lighting, heating and solvents according to DIN 51636
- aliphatic hydrocarbons: hexane, heptane, octane, nonane, decane
- aromatic hydrocarbons: benzene, toluol, xylol, solvent naphtha according to DIN 51633
- alcohol: propane, butane, ethane

Tank registrations

- For type 83 UV: DIN 6608, 6616, 6617, 6619, 6623, 6624 and TGL 5315
- For type 84 UVT: DIN 6608, 6616, 6617, 6619, 6624, and TGL 5315
- For type 81 D-Ex: DIN 6608, 6616, 6617, 6618, 6619, 6623, 6624, 4119 and TGL 5315 or other certified tanks for liquid storage

Accessories

- Overfill prevention sensor testing device type ME 5

Purchase Order Codes

Please state the following order number in your purchase order.

Overfill Prevention Sensor

Protective basket nickel-plated		without	0
		with	1
Coding for QSS		without	0
	Unleaded premium-grade petrol		1
	Diesel fuel		2
	Unleaded regular petrol		3
	Unleaded extra premium-grade petrol		4
	reserved		5
	reserved		6
Flanged insert		without	0
	Type 901		1
	Type 901 nickel-plated for QSS		2
	Type FP 901 ASS K nickel-plated for ASS		3
Plugs	Junction box for remote installation		1
	Pipe plugs (basis)		2
	Pipe plugs (basis) for ASS		3
	Junction box and wall plugs (bottom part) for remote installation		4
	Junction box and wall plugs (bottom part) for remote installation for ASS		5
	Junction box and wall plugs (bottom part) for remote installation for ASS with additional earth connector		6
Lengths of probes	Two-digit code: Length in mm / 100 (e. g. 1,500 mm = 15) 84 UVT only available with length 600 mm and 900 mm (code: 06 or 09)		
Type / probe tube	81 D-Ex U / stainless steel 24 x 1		0
	81 D-Ex / stainless steel 24 x 1		1
	83 UV / brass 24 x 2		2
	84 UVT (telescopic) / brass 24 x 2		3
Order Number	1110		

Individual Parts and Retroplugs

Product	Function	Order number
Pipe plugs complete type FP 907 / ASS 3 / K IP 68 with adapter union	Code 1 till 6	11191 / 1-6
Flanged insert type 901	without coding	111901
Flanged insert type FP 901 nickel-plated for QSS	Code 1 till 6	11290 / 1-6
Flanged insert type FP 901 ASS K nickel-plated for ASS	Code 1 till 6	11390 / 1-6
Wall plugs complete type 907		112910
Wall plugs complete type FPW 907 for QSS	Code 1 till 6	11292 / 1-6
Wall plugs complete type FPW 907 / ASS / K IP 68	Code 1 till 6	11293 / 1-6
Wall plugs complete type FPW 907 / ASS / K IP 68 with additional earth connector	Code 1 till 6	11294 / 1-6
Wall plugs bottom part		111902
Wall plugs bottom part nickel-plated for ASS		112920
Wall plugs bottom part nickel-plated for ASS with additional earth connector		112940
Protective basket nickel-plated		111903
Adapter union for ASS retroplug		111904
Seal white		111906
Screw-in cap for joint box Ms with seal		111909

For further information contact us on telephone +49/40/39 82 07-0

Current information under: www.fafnir.com

Coded Electrical Plug Connection Type FP 903/907 ASS K for QSS and ASS

The product recognition QSS is a device to prevent the mixing of fuels or other liquids during the filling of a storage or bunker tank from a road tanker.

The filling hose safety device ASS monitors the correct connection of the filling hose to such tanks. The FAFNIR QSS/ASS solutions consist of a plug on the tank and a coupling on the road tanker. The release signal for the filling process is performed by an amplifier in the road tanker that recognizes the correct pairing and functioning of the coupling connection. By the way, the overfill prevention sensor for filling stations is integrated into the overfill protection system via this coupling connection.



Coupling Type 903 ASS K
Wall plug Type 907 ASS K

Advantages of FAFNIR's Technology

- Robust design for application in a rough environment
- Simple functional structure for high operational safety
- Totally maintenance-free
- Coding principle tested and tried a million times
- Introduced in Europe as the standard for filling station systems
- Integrated solution for contacting overfill prevention sensors, QSS and ASS function

Our Terminology

Overfill prevention sensor: GWG
Quality assurance system or product recognition: QSS
Filling hose safety device: ASS

Function

The QSS functions are carried out by the simple pairing of magnetic reed sensor coding between the plug (wall plugs) and the mobile coupling. The analysis is based on the principle "2 out of 4", thus corresponding to a high safety standard. Six different codes are available.

The ASS function is performed by checking the closed circuit between amplifier, connection cable, plugs, filling nozzle, filling hose, and the hose connection inside the road tanker. ASS monitors the correct connection of the filling hose as well as that of the gas displacement device for gasolines.

Design

The coupling type 903 ASS K consists of:

- Connection cable
- Protective hose
- Coupling with:
 - GWG with contact sockets
 - Reed sensors
 - Push contacts

The wall plugs type 907 ASS K consist of:

- Wall plugs bottom part
- Flanged plug-in unit
- Magnets
- Protective basket

Coupling Connection

The coupling type 903 ASS K is suitable for all wall and tube plugs, connecting all GWGs according to TRbF 511 and TRbF 512. The QSS and ASS function is only established in connection with the plugs type 907 ASS K.

Electrical Connection

- Clamped connection in the amplifier
- 2 x 1 mm² for GWG circuit
- 7 x 0.25 mm² for QSS coding and ASS

Technical Data

Operating data:

- Ambient temperature: -25 °C to +50 °C
- Resistant to all products according to the GWG list of substances

Materials:

- Coupling:
- Connection cable: PUR
 - Protective hose: PA
 - Housing: PA6.6
 - GWG contact sockets: CuZn39Pb2 / Pb3, surface galvanised Ni 5 µm
 - Push contacts: VA

Wall plugs:

- Brass nickel-plated
- Protection class of housing IP 68

Dimensions:

Coupling:

- Connection cable: Ø 7 mm x 15 m standard
- Protective hose: Ø 16 mm x 1,000 mm
- Housing: Ø 60 mm x 137 mm
- Other data: see illustration

Wall plugs:

- Housing Ø 60 mm x 105 mm

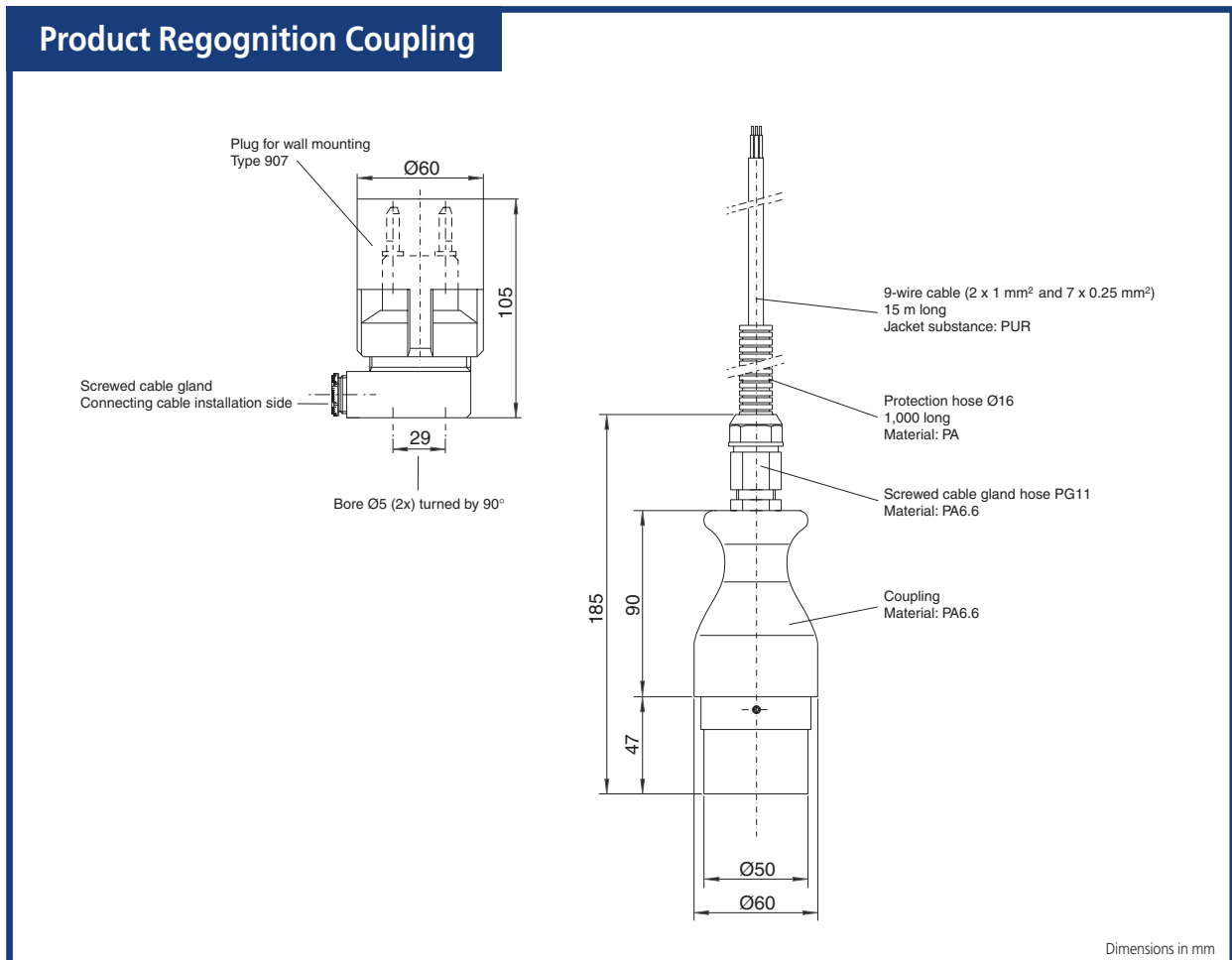

Purchase Order Codes

Please state the following order number in your purchase order.

Plugs Type 907/903 ASS K**Coding for QSS**

Unleaded premium-grade petrol	1
Diesel fuel	2
Unleaded regular petrol	3
Unleaded extra premium-grade petrol	4
reserved	5
reserved	6

Order number	1121
--------------	------

Coupling Type 903 ASS K

Cable length	15 m	1
	25 m	2

Order number	1122
--------------	------

For further information contact us on telephone +49/40/39 82 07-0

Current information under: www.fafnir.com

The Overfill Prevention Sensor Testing Device ME 5

Overfill prevention sensors must be checked on a regular basis. This is usually performed during a tank inspection. An optimal and safe check of overfill prevention sensors according to TRbF 511 is guaranteed by the overfill prevention sensor testing device ME 5.



Overfill prevention sensor testing Type ME 5

Advantages of FAFNIR's Technology

- Genuine function check
- Easy menu-driven operation
- Handy design
- Suitable for all overfill prevention sensors according to TRbF 511
- Certified for overfill prevention sensors in explosive atmospheres
- Simultaneous check of the QSS coding
- Driven by storage batteries
- Long-term charge

Our Terminology

Overfill prevention sensor: GWG
Quality assurance system or product recognition: QSS

Function

The GWG is heated up by the intrinsically safe current of the testing device. The heating time is measured, analysed and indicated in the LC-display. A switching off event is treated in the same manner. The QSS coding is registered and also displayed.

Connection to the GWG

The connection of the overfill prevention sensor testing device to the GWG is realised via a coupling type 903 with helix cable.

Design

The overfill prevention sensor testing device consists of:

- Coupling
- Helix cable
- Housing with:
 - Test electronics
 - Display
 - Foil-protected keyboard

