

Leak detection technology

For a clean and protected environment

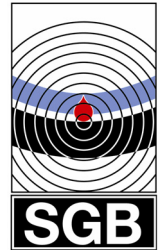

Underpressure leak detector VLR 410/E



weatherproof design

An underpressure leak detector for the continuous monitoring of double walled pipes

Each leak in one of the both walls will be detected, before conveyed product will enter the environment.

A leak detection system with the highest environmental protection level in accordance to the European standard EN 13160.

Liquids to be monitored

Water polluting liquids:

- with a flash point above $> 55^{\circ}\text{C}$, without potentially explosive vapours; e.g.: diesel

For the monitoring of pipes:

Approved and made out of metal or plastic

- up to 25 bar pressure in the primary pipe

Approval:

Germany: Z – 65.25 – 390

Type	Alarm ON	Pump OFF
VLR 410/E	$> 410 \text{ mbar}$	$< 540 \text{ mbar}$

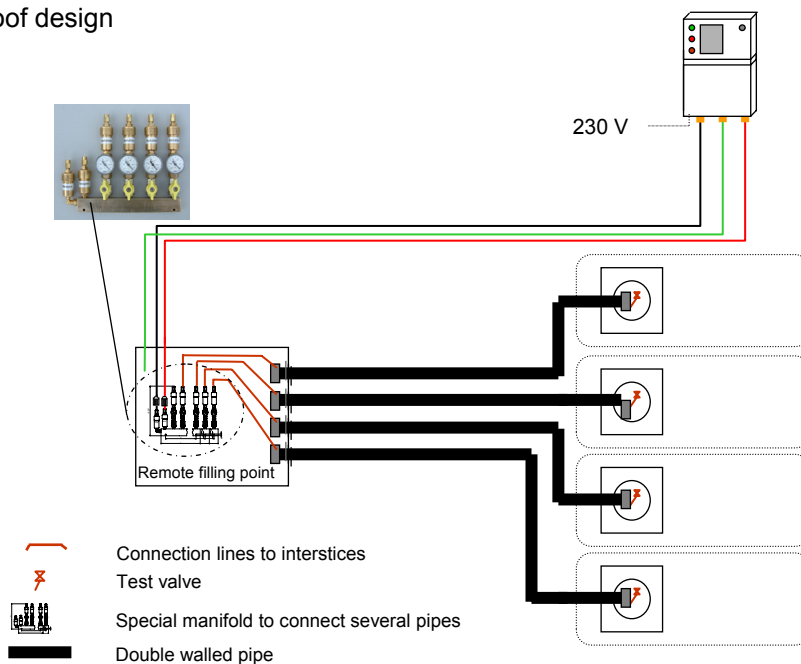

UK Distributor

t: +44 (0)1388 813433
f: +44 (0)1388 813307
sales@orangecounty.co.uk
www.orangecounty.co.uk

SGB GmbH
Hofstr. 10
Postfach: 21 07 41

D-57076 Siegen
D-57031 Siegen

Tel.: + 49 / (0) 271 / 48964-0
Fax: + 49 / (0) 271 / 48964-6
http://www.sgb.de
E-mail: sgb@sgb.de